



Stannah
An independent
family business
since 1867

Lowriser

Low rise platform lift

Up to 1m

Stannah

Notes:-

There must be no under-floor heating or any pipework in the area of the lift base and threshold.

The lift applies a maximum load of 5KN to the base.

A concrete base is required, with a minimum of 150mm depth.

The base and vertical face of the threshold must have a smooth finish and be level to within 5mm.

A minimum clearance of 2m is required above the first floor level.

Note: The threshold must be capable of withstanding a load of 2.5kN/fixing.

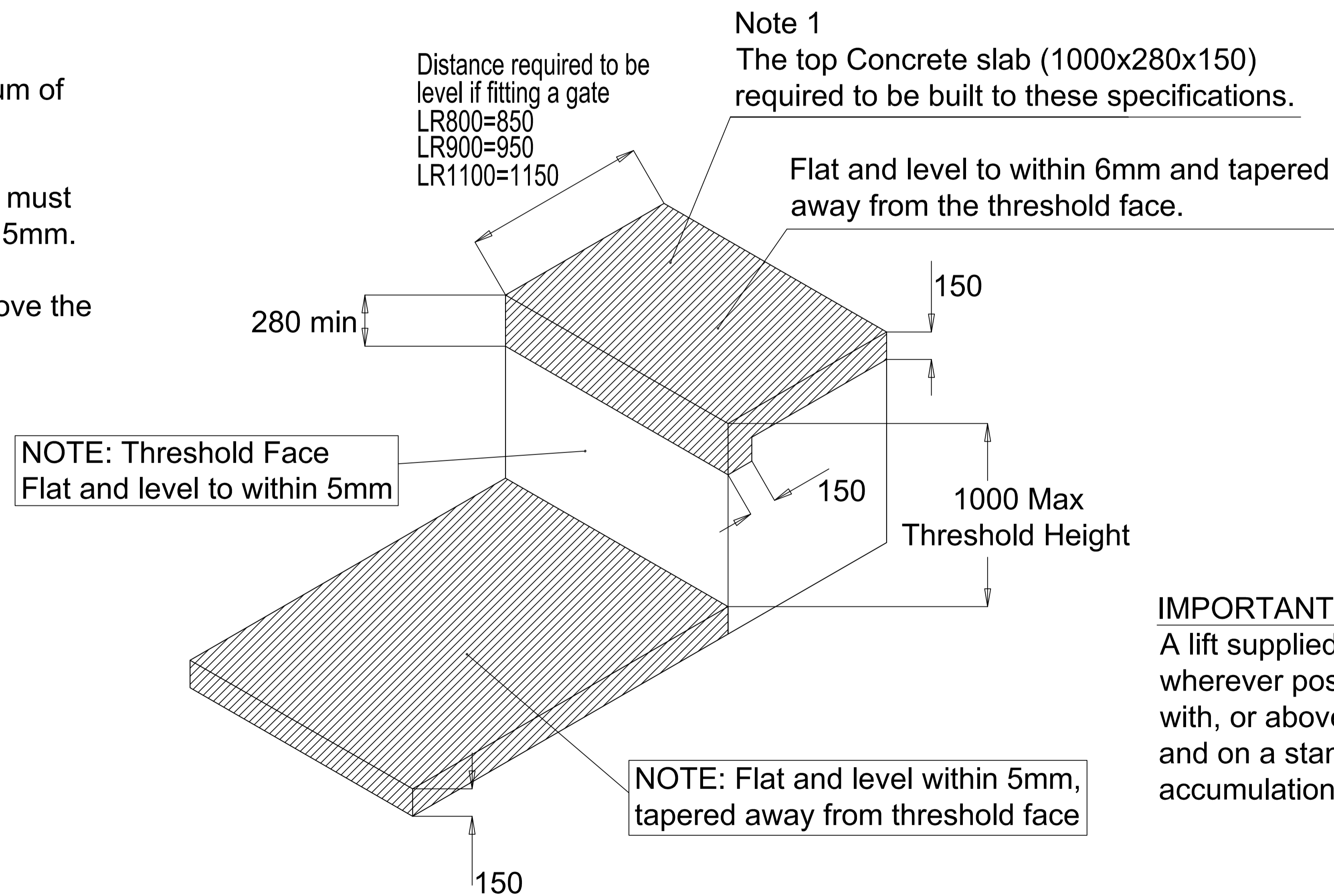

IMPORTANT NOTE

A lift supplied for external applications should wherever possible, be installed with it's base flush with, or above, the level of the surrounding ground, and on a standing which will remain free from accumulations of water.

Waiver:

This data sheet is for guidance only and must not be used for proper working drawings. Please contact Stannah Lifts for particular details before proceeding. Owing to our policy of continual improvement we reserve the right to alter specifications and dimensions without prior notice

Stannah lifts Ltd.
Anton Mill, Andover, Hampshire. SP10 2NX

Tel: 01264 339090

www.stannahlifts.co.uk

Information
sheet
LR 915
Rev A
20.02.12